

GGF Standard for the Quality of Thermally Toughened Soda Lime Silicate Safety Glass for Building

4.4 | OCTOBER 2004

Contents

1. Scope
 2. Definition, characteristics and manufacturing process.
 3. Range of toughened safety glasses
 4. Tolerances, dimensional characteristics
 5. Edgework
 6. Holes/cut-outs
 7. Shaped flat panes
 8. Visual appearance
 9. Glazing and Fixing
 10. Fracture characteristics
 11. Fragmentation test
 12. Identification
 13. Disclaimer
- Annex A Method of Measuring Roller Wave
- Annex B Examples of Particle Count

1. Scope

This document specifies the characteristics and associated measurement procedures and test methods for toughened (tempered) safety glass, incorporating British Standard BS EN 12150.

The dimensional and tolerance characteristics of toughened safety glass are specified and recommendations are made on the dimensions and tolerances of holes/cut-outs in toughened safety glass.

A test method is described for assessing the fragmentation of toughened safety glass to show how the quality and consistency of manufacturer can be controlled.

Other requirements, not specified in this standard, may apply to thermally toughened safety glass which is incorporated into assemblies, e.g. laminated glass or insulating units, or undergo an additional treatment, e.g. coating. The additional requirements are specified in the appropriate product standard.

Thermally toughened safety glass, in this case, does not lose its mechanical or thermal characteristics.

2. Definition, characteristics and manufacturing process

2.1 Toughened (tempered) safety glass

A single piece of float or non-wired cast, annealed soda-lime silica glass, subjected to a thermal process which greatly increases its resistance to mechanical and thermal stress and gives it prescribed fragmentation characteristics.

It is produced by subjecting annealed glass to a process of heating and rapid cooling which produces high compression in the surface and compensating tension in the centre to give it the characteristics described in 2.1.1. to 2.1.6.

2.1.1. Strength

In general the strength can be increased to as much as four to five times that of the equivalent thickness of annealed glass. The process does not increase the resistance of the surface to scratching or abrasion. The edges have similar vulnerability characteristics to those of all glasses.

2.1.2. Thermal Strength

It offers greatly increased resistance to both sudden temperature changes and temperature differentials up to 200°C compared with annealed glass (up to 40°C). The stress characteristics of toughened safety glass, of normal soda-lime silica composition, are unchanged for continuing service up to 250°C.

2.1.3 Fracture characteristics

In the event of breakage thermally toughened safety glass fractures into numerous small pieces, the edges of which are generally blunt.

Note: Fragmentation in service does not always correspond to that described in Section 11, due to restraint from fixing or

reprocessing (e.g. laminating), or due to the cause of fracture.

2.1.4. Loading: Wind, Snow

Although toughened safety glass is much stronger than annealed glass, because the Young's Modulus of elasticity of both glass types is the same, the deflection characteristics, thickness for thickness are identical. As a consequence, it is necessary to restrict deflection to an acceptable visual degree, rather than design purely according to strength.

2.1.5 Work on toughened safety glass

Toughened safety glass cannot be cut or drilled, and should not be surface or edge worked. All edgework, drilling and surface treatment, e.g.: sandblasting, acid embossing and brilliant cutting, should be carried out prior to toughening.

Toughened safety glass as manufactured is a finished product. However coatings can be applied (see 3.5).

2.1.6 Light and heat transmission

The toughened process does not alter the light transmission and solar radiant heat properties of the glass. These properties of the toughened product are identical to those of the annealed glass used.

2.2 Manufacturing process

There are two available methods of producing toughened safety glass.

2.2.1. Horizontally toughened safety glass

The glass is processed horizontally, supported on rollers also known as roller hearth toughened.

2.2.2. Vertically toughened safety glass

The glass is processed vertically, suspended by tongs.



Glass and Glazing Federation

44-48 Borough High Street
London SE1 1XB
Tel 0870 042 4255
Fax 0870 042 4266
www.ggf.org.uk

While every attempt is made to present up to date information, this data sheet, produced by the Glass and Glazing Federation, is issued for guidance but without responsibility for any advice given therein or omission therefrom or for the consequences of acting in reliance thereon and all liability on the part of the Glass and Glazing Federation however arising in connection therewith is expressly disclaimed.

2.3 Flat toughened safety glass

A product that has not been deliberately given a specific profile in the course of manufacture.

2.4 Curved toughened safety glass

A product that has been deliberately given a specific profile in the course of manufacture.

There is not a standard for this product as there is insufficient data available. However, the information given on thickness, edgework and fragmentation is also applicable to curved thermally toughened safety glass.

3. Range of toughened safety glasses.

3.1 Transparent toughened safety glass

Clear

Manufactured from clear float glass

Body tinted

Manufactured from float glass of uniform colouration throughout the body of the glass. Colours generally available are blue, bronze, green, grey and pink.

Surface coated

Manufactured from float glass, which has received, during manufacture, a surface treatment, which modifies the optical properties and/or surface emissivity.

3.2 Translucent toughened safety glass

Clear

Manufactured from clear, patterned glass.

Body tinted

Manufactured from patterned glass of uniform colouration throughout the body of the glass.

3.3 Enamelled toughened safety glass

This is also known as opaque toughened safety glass. This is manufactured from annealed glass which has had its surface coated with coloured ceramic frit, which is fired in during the toughening process. The enamel becomes an integral part of the glass surface. Colours should be specified in accordance with BS or RAL "specification for external cladding colours for building purposes". The manufacturers should be consulted regarding the availability of their standard and non-standard colour ranges.

3.4 Decorative toughened safety glass

This covers surface work on glass, e.g. acid embossing, sandblasting, brilliant cutting and engraving. This must be carried out prior to toughening. (See BS 952 Part 2 "Terminology for work on Glass" for descriptions of types of surface work). Certain types of screen-printing must be done prior to toughening where the colour medium requires firing in during the toughening process.

3.5 Others

Toughened safety glass as manufactured is a finished product, however, certain coatings, e.g. for solar control performance and improvement of surface emissivity and some decorative treatments e.g. certain types of screen printing, silvering, etc. can be applied subsequent to toughening.

4. Tolerances. dimensional characteristics

4.1 General

This section deals with methods of determination of tolerances on thickness, dimensions, squareness and flatness of panes; and glass thickness and maximum and minimum sizes normally available

4.2 Nominal thickness and tolerances

The nominal thickness and tolerances are shown in Table 1.

Table 1: Nominal thickness and thickness tolerances

Dimensions in millimeters

Nominal Thickness <i>d</i>	Thickness tolerances for glass type	
	Patterned	Float
3	± 0.5	± 0.2
4	± 0.5	± 0.2
5	± 0.5	± 0.2
6	± 0.5	± 0.2
8	± 0.8	± 0.3
10	± 1.0	± 0.3
12	non manufactured	± 0.3
15		± 0.5
19		± 1.0
25		± 1.0

4.2.1 Method of measurement

The thickness of a pane is calculated as the average of the measurements carried out to the nearest 0.01 mm taken at the centres of four edges. For vertically toughened glass, measurements should be made centrally between tong marks and a minimum of 50 mm in from the edge.

The minimum and maximum values, rounded to the nearest 0.1 mm, must be within tolerances shown in Table 1.

Note: For cast/patterned glass the measurements must be made by means of an instrument of the calliper micrometer type with plates of a diameter of 55 mm.

4.2.2 Maximum and minimum sizes normally available

Minimum size of pane is dependant on method of toughening. For horizontally toughened safety glass the minimum size of pane should generally not be less than 300 mm x 100 mm, but the manufacturer should always be consulted for minimum and maximum sizes normally available.

4.3.1 General

When thermally toughened safety glass

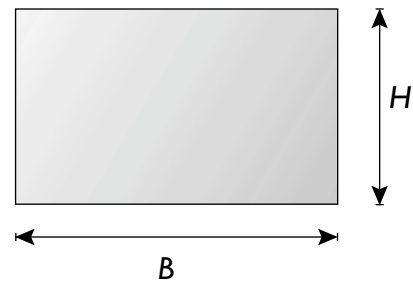
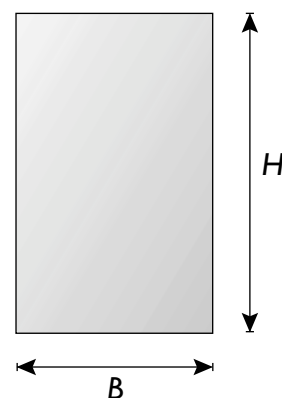

Figure 1: Examples of width, B and length, H, relative to the pane shape



dimensions are quoted for rectangular panes, the first dimension shall be the width, B, and the second dimension the length, H, as shown in Fig.1. It shall be made clear which dimension is the width, B, and which is the length, H, when related to its installed position.

4.3.2. Tolerances and squareness

The nominal dimensions for width and length being given, the finished pane shall not be larger than a prescribed rectangle resulting from the nominal dimensions increased by the tolerance, t, or smaller than a prescribed rectangle reduced by the tolerance, t. The sides of the prescribed rectangles are parallel to one another and these rectangles shall have a common centre (see Figure 2). The limits or squareness are also the prescribed rectangles. Tolerances are given in Table 2.

Dimensions in millimeters

Nominal dimension of side, B or H	Tolerance, t	
	nominal glass thickness $D \leq 12$	nominal glass thickness $d > 12$
≤ 2000	± 2.5 (horizontal tightening) ± 3.0 (vertical toughening)	± 3.0 ± 0.2 ± 0.2 ± 0.3 ± 0.3
$2000 < B$ or $H \leq 3000$	± 3.0	± 4.0
> 3000	± 4.0	± 5.0

Table 2: Tolerances on width, B, and length H

4.3.3. Edge deformation produced by vertical toughening

The tongs used to suspend the glass during toughening result in surface depressions, known as tong marks (see Figure 3). The centres of the tong marks are situated up to a maximum of 20 mm in from the edge. A deformation of the edge less than 2 mm can be produced in the region of the tong mark and there may also be an area of optical distortion. These deformations are included in the tolerances in Table 3

4.3.4. Flatness

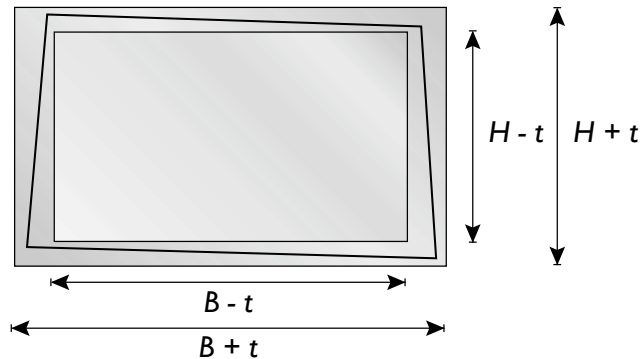

Figure 2: Tolerance limits for dimensions of rectangular panes

4.3.4.1 General

By the very nature of the toughening process, it is not possible to obtain a product as flat as annealed glass. The difference depends on the nominal thickness, the dimensions and the ratio between the dimensions. A distortion known as bow can occur. There are two kinds of bow (see Figure 4):

Overall or general bow¹⁾

Local bow²⁾

Note 1): Overall bow can, in general, be accommodated by the framing system.

Note 2): Local bow needs to be allowed for in the glazing materials and weather seals. For special requirements the manufacturers should be consulted.

4.3.4.2 Measurement of overall bow

The pane of glass shall be placed in a vertical position and supported on its longer side by two load bearing blocks at the quarter points (see Figure 5).

The deformation shall be measured along the edges of the glass and along the

diagonals, as the maximum distance between a straight metal ruler; or a stretched wire, and the concave surface of the glass (see Figure 4).

The value for the bow is then expressed as the deformation, in millimetres, divided by the measured length of the edge of the glass, or diagonal, in mm, as appropriate. The measurement shall be carried out at room temperature.

4.3.4.3 Measurement of local bow

Local bow can occur over relatively short distances on the edges of the glass. Local bow shall be measured over a limited length of 300 mm by using a straight metal ruler; or a stretched wire, parallel to the edge at a distance of 25 mm from the edge of the glass (see Figure 4).

Local bow is expressed as millimetres/300 mm length.

For patterned glass, local bow shall be determined by using a straight metal ruler resting on the high points of the pattern and measuring to a high point of the pattern.

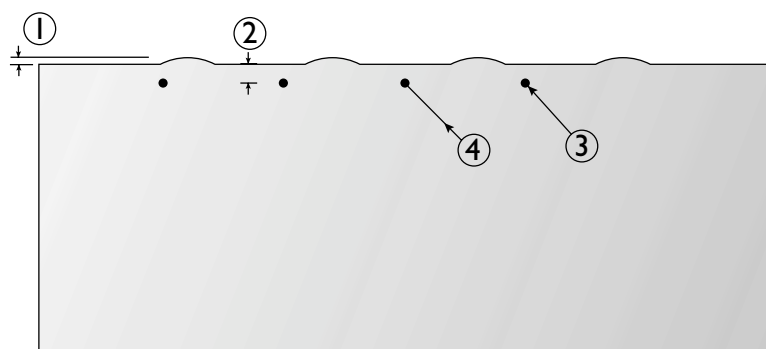

1. Deformation
2. Up to 20 mm
3. Tong mark

4. 100 mm radius maximum area of optical distortion

Figure 3: Tong mark deformation

Toughening Process	Type of glass	Maximum values	
		Overall bow mm/mm	Local bow mm/300 mm
Horizontal	Float to EN 572-2	0,003	0,5
	Others	0,004	0,5
Vertical	All	0,005	1,0

Table 3: Maximum values for overall and local bow

4.3.4.4 Limitation on overall and local bow

The maximum allowable values for the overall bow, when measured according to 4.3.4.2, and local bow, when measured according to 4.3.4.3, for glass without holes and/or notches and/or cutouts are given in Table 3.

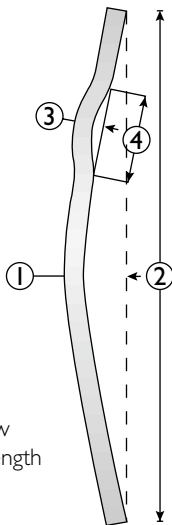

- 1. Deformation for calculating overall bow
- 2. B, or H, or diagonal length
- 3. Local bow
- 4. 300mm length

Figure 4: Representation of local or overall bow

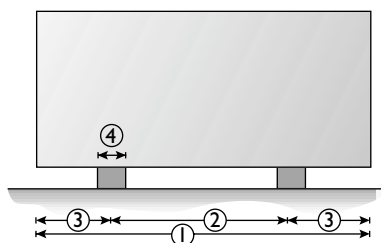

- 1. B or H
- 2. B/2 or H/2
- 3. B/4 or H/4
- 4. Maximum 100mm

Figure 5: support conditions for the measurement of overall bow

5. Edgework

5.1 General

Any edge working must be in accordance with BSEN 12150 Part 1. It is important that the edge remaining after mitre bevelling is not less than 2mm or 1/3rd of the thickness, whichever is the larger. Normally every glass, which is to be thermally toughened, has to be edge worked prior to toughening. The simplest type of edge working is the arressed or finished edge (see Figure 6a). Other common types are shown in Figures 6 b) to 6 d). For specialist edge work, such as water jet cutting, or "as cut" edges the manufacturers should be consulted.

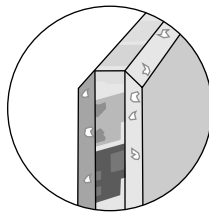

Figure 6a: Arressed edge (with blank spots)

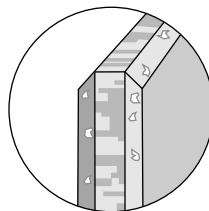

Figure 6b: Ground edge (with blank spots)

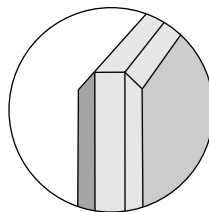
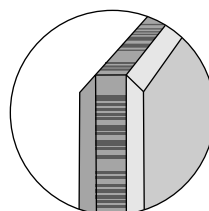

Figure 6c: Smooth ground edge (no blank spots)



5.2 Profiled edges

Various other edge profiles can be manufactured with different types of edgework. The manufacturer should be consulted.

6. Holes/Cut-Outs

6.1 Warning

Thermally Toughened Safety glass should not be cut, sawed, drilled or edgeworked after toughening.

6.2 General

This section deals with the types, sizes and position of holes/cut outs that can be incorporated within toughened safety glass of thickness of 4 mm and greater. Tolerances are given on hole/cut-out size and position. Comments are made on the quality of edgework-associated holes/cut-outs.

Where there are more than four holes in a pane or the total area of all holes exceeds one sixth of the plate area, the manufacturer should be consulted.

6.3 Round Holes

6.3.1 General

This standard considers only round holes in glass that is not less than 4mm nominal thickness. The manufacturers should be consulted about edge working of holes.

6.3.2 Diameter of holes

The diameter of holes (ϕ), shall not, in general, be less than the nominal thickness of the glass. For smaller holes, the manufacturers should be consulted.

6.3.3 Limitations on position of holes

In general, the limitations on hole positions relative to the edges of the glass pane, the corners of the glass pane and to each other depends on:

- The nominal glass thickness (d);
- The dimensions of the pane (B, H);
- The diameter of hole (ϕ);
- The shape of the pane;
- The number of holes.

The recommendations given below are those, which are normally available and are limited to panes with a maximum of 4 holes.

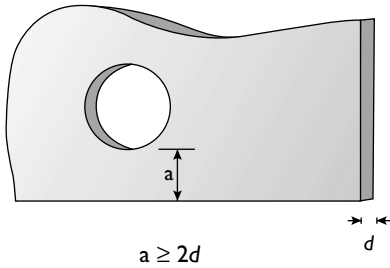

Figure 7: Relationship between hole and edge of pane

1) The distance, a, of the edge of a hole to the glass edge should be not less than 2d.

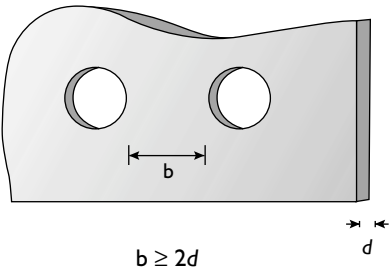

Figure 8: Relationship between two holes

2) The distance, b between the edges of two holes should be not less than 2d.

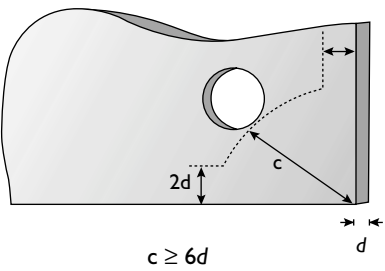

Figure 9: Relationship between hole and corner of pane

3) The distance, c, of the edge of a hole to the corner of the glass should not be less than 6d.

Note: If one of the distances from the edge of the hole to the edge of the glass is less than 35mm, it can be necessary to position the hole asymmetrically with respect to the corner. The manufacturers should be consulted.

6.3.4 Tolerances on hole diameters

The tolerances on hole diameters are given in Table 4

Dimensions in millimetres

Nominal hole diameter	Tolerances
$4 \leq \phi \leq 20$	$\pm 1,0$
$20 < \phi \leq 100$	$\pm 2,0$
$100 < \phi$	Consult the manufacturer

Table 4: Tolerances on hole diameters

6.3.5. Tolerances on positions of holes

The tolerances on positions of holes are the same as the tolerances on the width, B, and the length, H, (see Table 3). The positions of holes are measured in two directions at right angles (x- and y-axes) from a datum point to the centre of the holes. The datum point is generally chosen as a real or virtual corner of the pane (see Figure 10 for examples) The position of a hole (X,Y) is $x \pm t, y \pm t$, where x and y are the required dimensions and t is the tolerance from Table 3.

NOTE: The manufacturers should be consulted if tighter tolerances on hole positions are required.

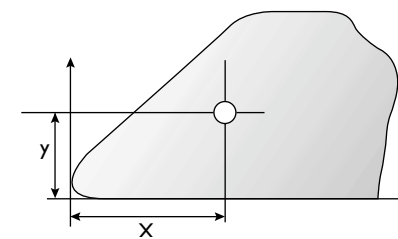
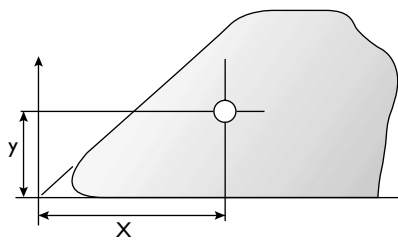

6.4 Notches and cutouts

Many configurations of notches and cutouts can be supplied. The manufacturers should be consulted about edge working of notches and cut-outs.

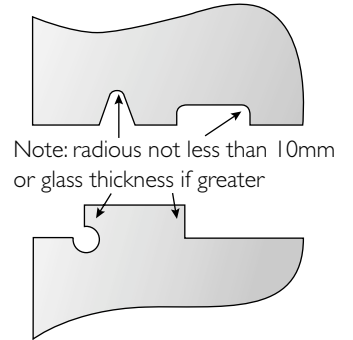

Note: radius (minimum 10mm) not less than glass thickness.

Figure 11: Examples of notches

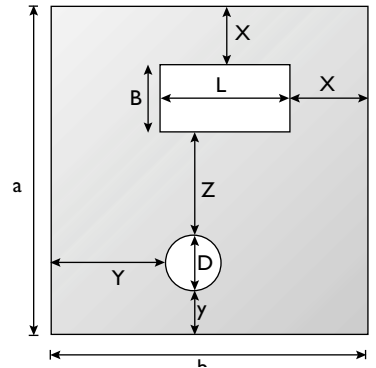

Figure 11a: Examples of Cut-outs

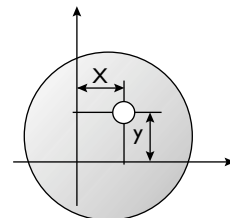
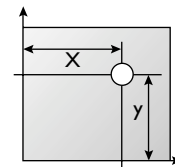

Figure 10: Examples of the positioning of holes relative to the datum point

B, L and D all less than $a/3$, or $b/3$, whichever is the smaller;
 X and x not less than the smaller of $L/2$ or $B/2$;
 Y and y not less than $D/2$;
 Z not less than the larger of $B/2$, or $L/2$ and $D/2$
 Note: the Manufacturer should be consulted about edge working of notches and cutouts.

7. Shaped flat panes

7.1 General

Many different shapes of pane, other than rectangular, can be manufactured. There are more variations available with horizontal toughening than with vertical Toughening but, because of the number of variations, the manufacturers should be consulted.
 Shapes can be produced either from templates or from fully dimensioned drawings. The manufacturer should be consulted as to which is the more appropriate, for the shapes required.

7.2 Templates

Accurate templates must be supplied for each pane with sufficient information to determine clearances and allowances required to manufacture. Templates must be of sufficient rigidity and of such suitable material so as not to distort the desired finished size.

8. Visual appearance

8.1 General

This section covers optical quality i.e. distortion of the glass which is visible in reflection, visual quality, i.e. defects on or within the glass, which can be seen in transmission, and colour consistency, i.e. changes in hue, which can be seen in either transmission and/or reflection.

8.2. Optical distortion

8.2.1 General

The toughening process will inevitably result in a product whose optical quality is lower than that of the glass from which it is produced.
 Surface distortion is produced by a reduction in the surface flatness, which can be seen particularly in reflection. This can be exacerbated when the glass used is body tinted, surface coated (including post-toughening coating) or enamelled and/or incorporated into double-glazing units.

8.2.2 Thermally toughened safety glass produced by vertical toughening

The distortion is generally of a random nature. However, the tong marks can produce additional optical distortion, which is generally in an area of radius 100 mm centred on the tong mark (see Figure 3)

8.2.3 Thermally toughened safety glass produced by horizontal toughening

While the hot glass is in contact with the rollers during the toughening process, a surface distortion is produced by a reduction in surface flatness, known as roller wave. Roller wave is generally noticed in reflection.

Glass, which is 8 mm or thicker, may show signs of small imprints in the surface (roller pick-up). As a general rule, the degree of distortion will be less with horizontally toughened glass than with vertically toughened glass.

8.2.4. Roller wave limits

Table 5 gives the roller wave limits for toughened float glass products.

Float glass Nominal thickness	Roller wave maximum mm
3, 4 and 5	0.5
6, 8 and 10	0.3
12, 15, 19, 25	0.15

Table 5: Roller wave limits

On toughened sheet glass, or toughened patterned glass, it is not possible to measure roller wave, due to the inherent distortion of the basic glass. The Method of Measuring Roller Wave will be found in Annex A

8.3 Anisotropy (iridescence)

The toughening process produces areas of different stress in the cross section of the glass. These areas of stress produce a bi-refracting effect in the glass, which is visible in polarised light.

When thermally toughened safety glass is viewed in polarized light, the areas of stress show up as coloured zones, sometimes, known as "leopard spots". Polarised light occurs in normal daylight. The amount of polarized light depends on the weather and the angle of the sun. The bi-refracting effect is more noticeable

either at a glancing angle or through polarized spectacles.

8.4 Visual quality

8.4.1. Body faults, e.g. seeds, bubbles

The number, size and distribution of seeds, bubbles, etc. are defined for the glasses under consideration in the appropriate parts of BS.EN 572.

No change will occur as a result of the toughening process.

Assessment of body faults should be undertaken using the method/criteria given, for the basic glasses in the appropriate parts of BS.EN 572.

8.4.2 Surface faults e.g. scars, scratches

Toughened safety glass shall be deemed acceptable if the following phenomena are neither obtrusive nor bunched: hairlines or blobs; fine scratches not more than 25mm long; minute imbedded particles. Obtrusiveness of blemishes shall be judged by looking through the glass, not at it, when standing at right angles to it on the room side at a distance of not less than 3 metres in natural daylight and not in direct sunlight. The area to be viewed is the normal vision area with the exception of a 50mm wide band around the perimeter of the glass.

Pattern ghosting can occur on glasses with a textured finish.

8.5 Colour consistency

8.5.1 Body tinted glass

Toughening will not produce any significant variation in colour. However, if a piece of toughened body tinted glass is placed next to a piece of annealed body tinted glass there may be a discernible difference.

A far larger problem will occur if different thicknesses of body-tinted glass are placed side by side as the colour is throughout the glass thickness. This can occur in those areas where toughened safety glass is required and an attempt is made to use the increased strength of the toughened safety glass by reducing the thickness of the glass. Body tinted glass from different manufacturers, or from different batches from the same source manufacturer can show different shades.

8.5.2 Surface coated glass

As a general rule those surface coated glasses which can be toughened may exhibit different visual characteristics or a slight colour variation as a result of toughening. Care should be taken to ensure that the coated surface is not contaminated before toughening by, for example grease, sweat, etc, as these materials may be burnt in during the toughening process. This could produce patches on the coating where there is a significant colour variation.

Glass, which is coated after toughening, will be within the same manufacturer's colour tolerance as coated annealed glass.

8.5.3 Enamelled toughened safety glass

With this product the 'colour' results from the firing in of a ceramic frit. No colour variation will result from the toughening process itself. However, the manufacturer should be consulted as to the likely tolerances on the colour and the possible variation between batches of ceramic frit. There is also a possibility that a colour variation may be noticeable if panes of different glass thickness or from different glass suppliers.

9. Glazing and fixing

9.1 General

Glazing should be in accordance with BS6262, BS 8000 Part 7, Glass and Glazing Federation Glazing Manual or other appropriate standard.

Thermally toughened safety glass conforming to BS 6206 and or BSEN 12600 meets the safety glazing requirements of Building Regulations and BS 6262: Part 4

Appropriate edge clearances must always be allowed taking into account glass type, e.g. clear or solar control and either single or double-glazed. Suitable insulation or cushioning should be used to prevent contact with hard materials.

9.2 Use of mechanical fixings

Glass to metal contact must be eliminated at all times by the use of gaskets, bushes, linings and setting blocks.

These should be of appropriate material, which has been approved by the toughened safety glass manufacturer. All fittings to which the glass is to be clamped must be free from high spots and/or burrs. Care should be taken to ensure that when the glass is being clamped the clamping pressure is evenly distributed.

10. Fracture characteristics

The actual size/shape of fragments will depend on the type of loading, e.g. hard body impact, soft body impact or uniformly distributed, causing the breakage.

In the majority of applications toughened glass is regarded as a safety material therefore it should comply with the requirements of BS EN 12,600 which is a semi-hard body.

When toughened glass is tested in accordance with BS EN 12,600, it shall either not break or if it breaks the ten largest crack free particles remaining 3 minutes after impact shall weigh no more than the equivalent weight of 6500mm² of the original material.

11. Fragmentation test

11.1 General

The fragmentation test determines whether the glass breaks in the manner prescribed for a thermally toughened safety glass

11.2 Dimensions and number of test specimens

The dimensions of the test specimens shall be 360 mm x 1100 mm, without holes, notches or cutouts.

Five specimens shall be tested.

11.3 Test procedure

Each test specimen shall be impacted, using a pointed steel tool, at a position 13 mm from the longest edge of the test specimen at the mid-point of that edge, until breakage occurs (see Figure 12).

Note: The fragmentation characteristics of glass are unaffected by temperatures between -500°C and +1000°C.

Examples of steel tools are a hammer of about 75g mass, a spring loaded centre punch, or other similar appliance with a hardened point. The radius of curvature of the point should be approximately 0.2 mm.

The test specimen shall be laid flat on a table without any mechanical constraint. In order to prevent scattering of the fragments, the specimen shall be simply held at the edges, e.g. by a small frame, adhesive tape etc., so that the fragments remain interlocked after breakage yet extension of the specimen is not hindered

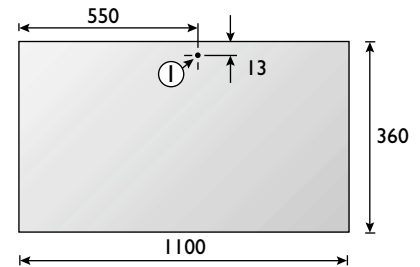

Figure 12: Position of impact point

1 Impact Point

Note: for thermally toughened safety glass manufactured by vertical toughening, the impact point shall not be on the long mark edge.

11.4 Assessment of fragmentation

The particle count and measuring of the dimensions of the largest particle shall be made between 4 to 5 minutes after fracture. An area of radius 100 mm, centred on the impact point, and a border of 25 mm, round the edge of the test specimen (see figure 13), shall be excluded from the assessment.

The particle count shall be made in the region of coarsest fracture (the aim being to obtain minimum value). The particle count shall be made by placing a mask of (50± 1) mm x (50± 1) mm on the test piece (see Annex B). The number of crack-free particles within the mask shall be counted. (See Table 6). A particle is crack-free if it does not contain any cracks, which run from one edge to another (see figure 14).

In the particle count, all particles wholly contained within the area of the mask shall be counted as one particle each and all the particles, which are partially within the mask, shall be counted as 1/2 particle each (see Annex B).

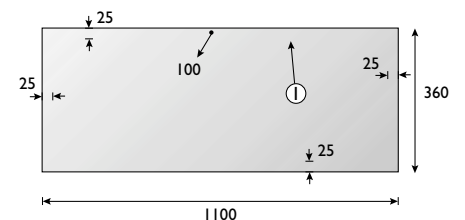

Area to be excluded

Figure 13: Area to be excluded from the particle count determination and largest particle measurement.

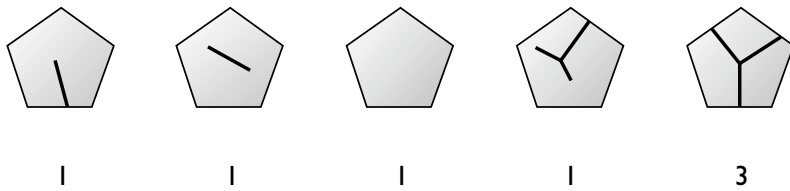

Figure 14: Examples of crack-free particles and the assessment regarding the number

11.5 Minimum values from the particle count

In order to classify a glass as a thermally toughened safety glass, the particle count of each test specimen shall not be less than the values given in Table 6.

Glass type	Nominal thickness (d) in mm	Minimum particle count
Float and draw sheet	3	15
	4 to 12	40
	15 to 19	30
Patterned	4 to 10	30

Table 6: Minimum particle count values

11.6 Selection of the longest particle

The longest particle shall be chosen from the body of the test specimen. It shall not be in the excluded area (see 11.4)

11.7 Maximum length of longest particle

In order to classify the glass as thermally toughened safety glass, the length of the longest particle shall not exceed 100 mm.

12 Identification

12.1 BS EN 12150 - Thermally Toughened Soda Lime Silicate Safety Glass - Part 2 - Evaluation of Conformity

Toughened Soda Lime Silicate safety glass shall be marked and/or labelled in accordance with the above standard.

12.2 Marking

Thermally toughened safety glass conforming to BS 6206 and/or BS EN12150 shall be permanently marked before installation in a position to remain visible after installation. The marking shall give the following information:

- name or trademark
- number of the standard
- classification level
- the word "toughened" or the letter "T"

13.Disclaimer

It is the responsibility of the user to ensure that the products and materials are appropriate for the particular application and that such application complies with all relevant local and national legislation, standards, codes of practice and other requirements.

The Glass and Glazing Federation hereby disclaim all liability whatsoever arising from any error or omission in this publication and for all consequences of relying on it.

Annex A: Method of Measuring Limits for Roller Wave

A1. Apparatus

The apparatus consists of an aluminium channel, 350 mm long, with a centrally mounted dial gauge.

A2. Method

The apparatus is placed on the glass at right angles to the roller wave, so that it can bridge from peak to peak of the wave (figure A1).

Figure A1: Place the apparatus across the roller wave

The apparatus is then moved along its axis until the dial gauge reads the highest

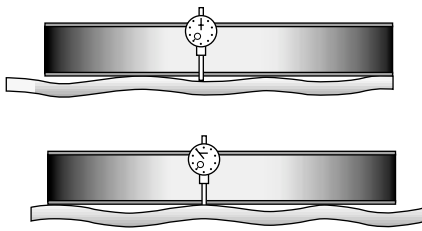

Figure A2: Set the zero of the gauge on a peak of the roller wave.

Value (Figure A 2).

At this point, the dial gauge is resting on a peak of the roller wave. The scale of the gauge is positioned (rotated) so that the needle points to 0 (zero) on the scale.

The apparatus is then moved again along its axis until the gauge reads the lowest value (Figure A3). At this point, the dial gauge is resting in the lowest point of the trough.

The reading is then taken, and the depth of the roller wave is the difference between the zero point and the reading

Figure A3: move the apparatus to take the lowest reading.

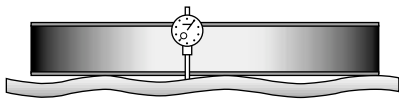

NOTE: The dial gauge scale is usually arranged so that a positive value is obtained by raising the post. Care should be taken to not misread the depth of the roller wave.

The roller wave depth is recorded to the nearest 0.05 mm. The above procedure can be performed several times on the same pane, giving a variety of answers, since the roller waves are unlikely to be consistent. The worst roller wave of those recorded is the value of the pane.

A3. Limitations

A3.1 Pane Size

The apparatus should only be used on panes with a dimension larger than 600 mm at right angles to the roller wave.

There is an exclusion area, 200 mm from the edge of the pane.

A3.2 Bow

A true measurement of roller wave can only be obtained on an otherwise flat pane of glass. If the pane has an overall bow, this will contribute to the value measured by the roller wave and must be taken into account. In the factory, this can be reduced by laying the pane of glass flat on a table, which will reduce the overall bow in the pane due to the self weight of the pane, particularly with larger panes.

The apparatus is accurate only when used in a factory to measure roller wave in panes laid flat on a table.

A3.3. Measurement on site

There will always be requests for site measurement of roller wave.

Measurements taken on site will be incorrect if the pane has any bow in it. This will be particularly the case if the pane is one side of an insulating glass unit, since insulating glass units are nearly always bowed in or out, from variations in air pressure. However, even single panes may be bowed in situ, either by innate overall bow (allowed up to 2 mm/m) or due to distortion induced by the fixing or framing system. Site measurement of roller wave should take into account the overall bow of the pane, especially if the pane is part of an insulating glass unit.

Annex B Examples of particle count

Figure B1 (see below) Select the area of coarsest fracture, place the template on the test specimen and draw round the template.

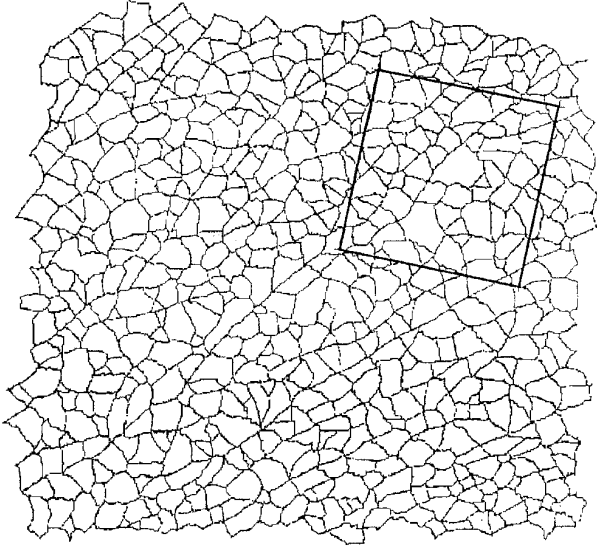

Figure B2 (see below) Mark and count the perimeter fragments as half particle each.

Number of perimeter particles = $32/2 = 16$

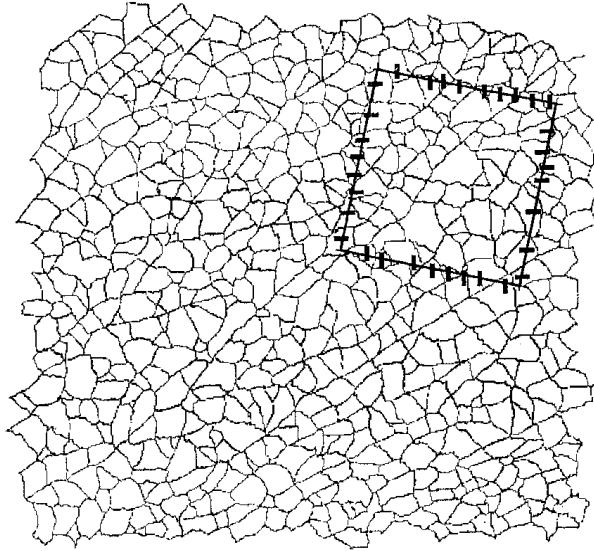
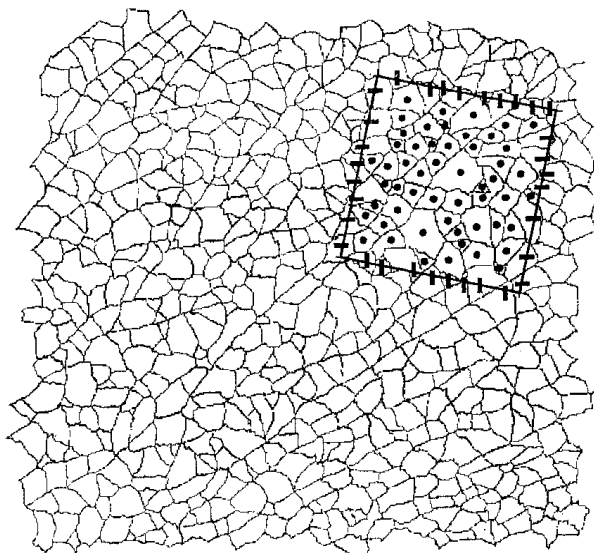

Figure B3 (see below) Mark and count the central fragments and add these to the perimeter count to obtain the particle count for the specimen.

Number of central particles = 53

Total number of particles = $16 + 53 = 69$



Bibliography

BS EN 12150-1: Glass in Building - Thermally Toughened Soda Lime Silicate Safety Glass - Part 1: Definition and Description.

BS EN 12150-2: Glass in Building - Thermally Toughened Soda Lime Silicate Safety Glass - Part 2: Evaluation of Conformity

BS EN 12600: Glass in Building - Pendulum Test - Impact Test Method for Flat Glass and Performance Requirements.

BS 952 Part 2: Terminology for Work on Glass.

BS EN 572-1: Glass in Building - Basic Soda Lime Silicate Glass products - Part 1 Definitions and General Physical and Mechanical Properties.

BS 6262 Part 4: Safety Related to Human Impact.

BS 8000 Part 7: Code of Practice for Glazing.

BS 6206: Specification for Impact Performance Requirements for Flat Safety Glass and Safety Plastics for Use in Buildings.

